

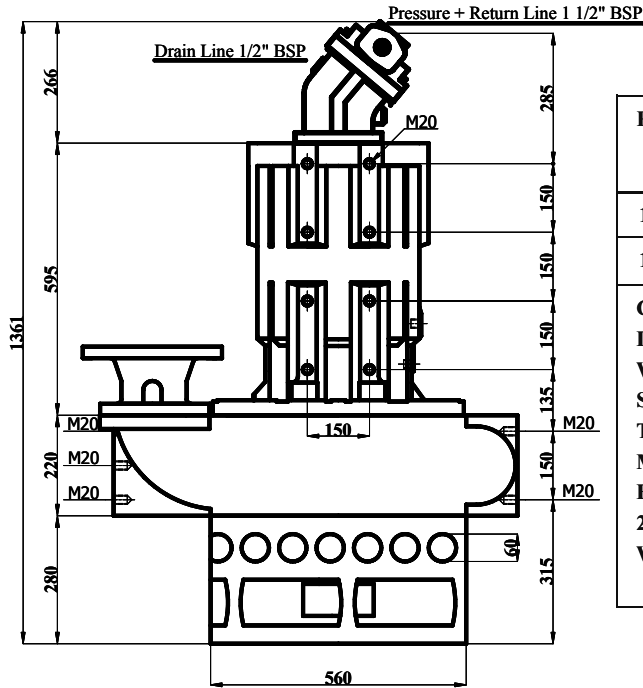

# SAND PUMP BY HYDRAULIC DREDGING SYSTEMS

200mm/8 Inch - 93KW/125HP - Hydraulic 125cc Piston Motor

LOW SPEED - LOW WEAR



RPM	Q m <sup>3</sup> /h	H meter	KW - HP	Operating Pressure BAR	Oil Flow l/min
1050	500	16	62 - 83	275	140
1200	550	22	93 - 125	350	160

CONTINUOUS DUTY AT LOW SPEEDS  
 IMPELLER WIDTH 70mm - STRAINER 60mm  
 WEAR PARTS CHROM CASTING  
 SHAFT 42 Cr Mo4 - DIN 7225 - Seawater DIN 1-4057  
 TORQUE 2 Nm / BAR  
 MAX CONTINUOUS OIL PRESSURE 430 BAR  
 EXCAVATOR MOUNTING PADS  
 2K - PAINT  
 WEIGHT 830 KG

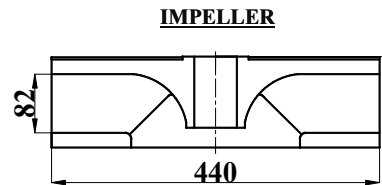
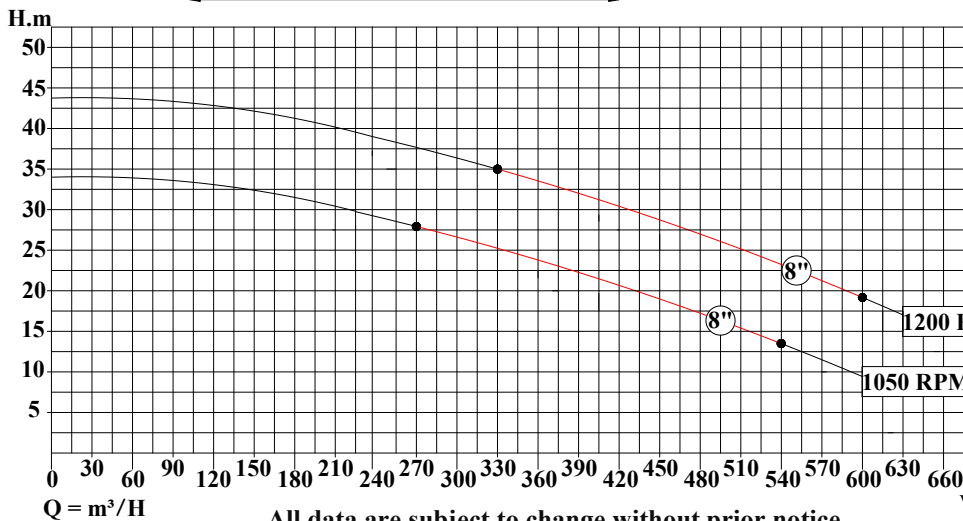
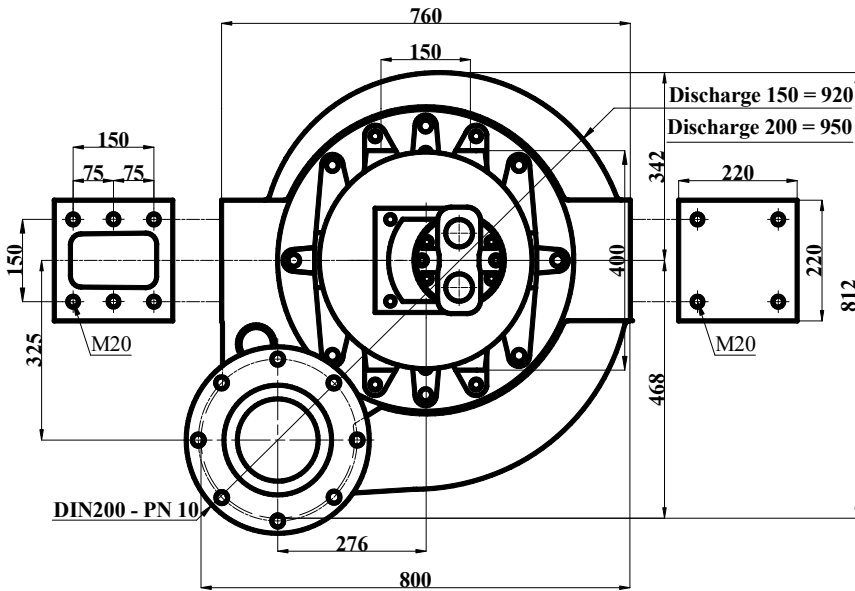

All data are subject to change without prior notice.

WEBSITE : [www.hdsbelgium.com](http://www.hdsbelgium.com)

E - mail : [hds@hdsbelgium.com](mailto:hds@hdsbelgium.com)